

I2C PULLUP (DEPOP -- PULLUPS ON MCU BOARD FOR MASTER MCU)

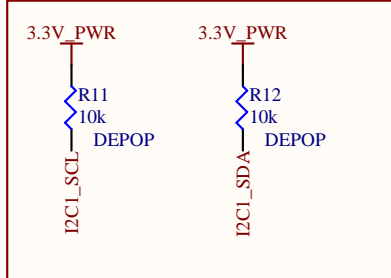

FLEX CONNECTOR

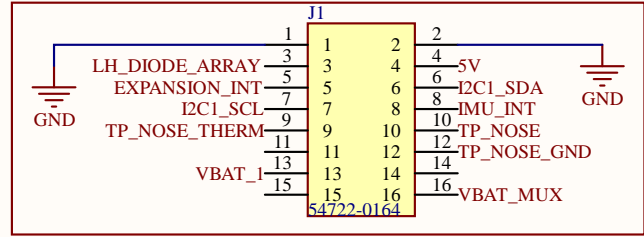

TEST POINTS

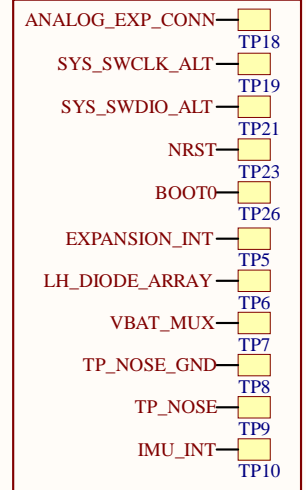

PROGRAMMER TAG BREAKOUT

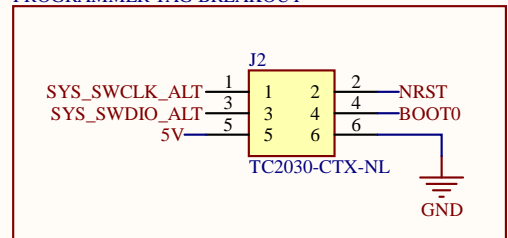

RF 32MHz CRYSTAL

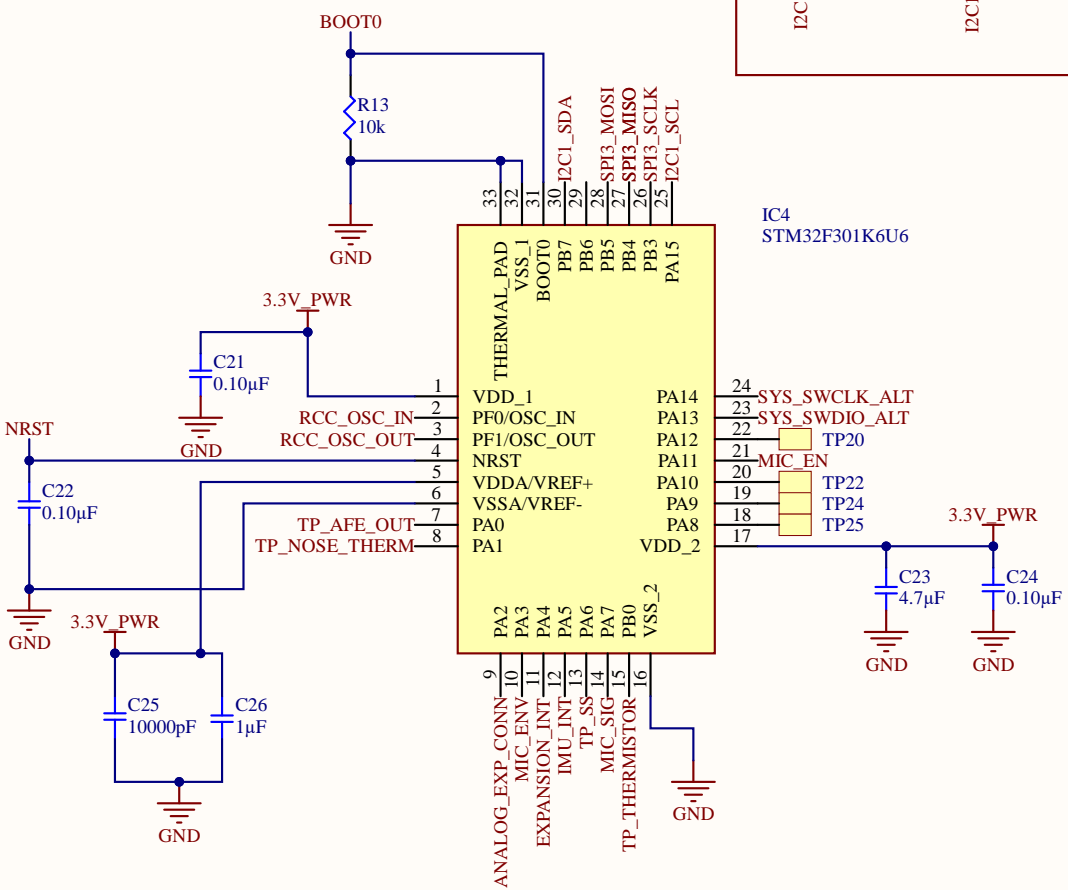
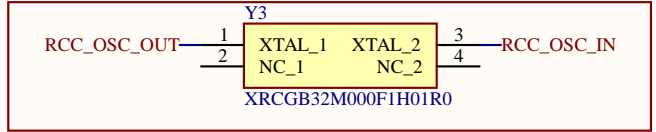

Title
MICROCONTROLLER

Size	Number	Revision
A		
Date:	3/26/2020	Sheet of
File:	D:\OneDrive - Massachusetts Institute of Technology\SCAMROUS\CHD\ALEK	

BATTERY MUX

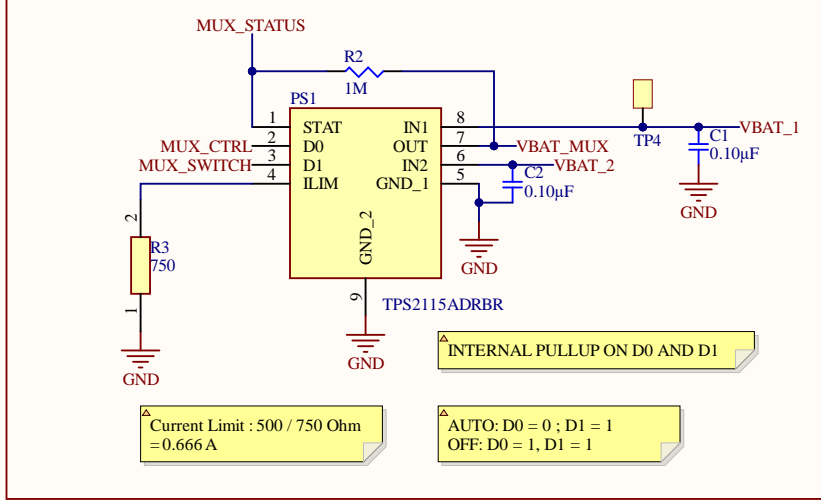

BATTERY INPUT

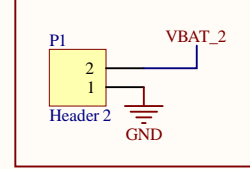

EXPANSION CONNECTOR

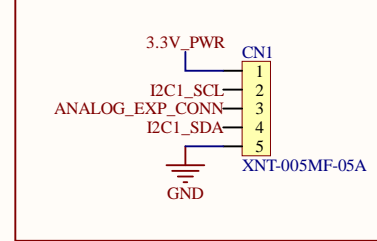

MICROPHONE POWER

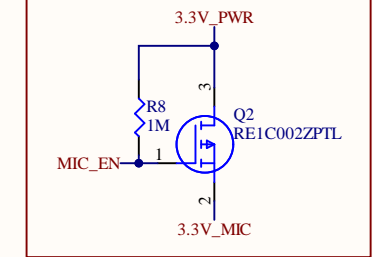

REGULATOR

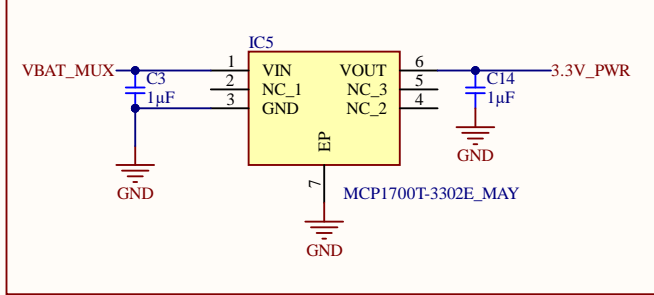

CHARGING CIRCUIT

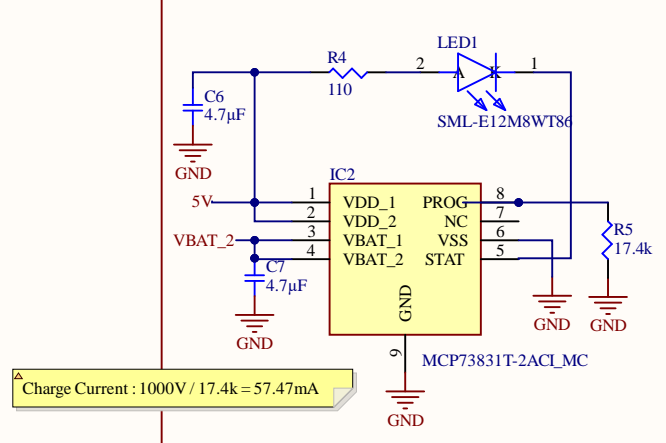

POWER SWITCH

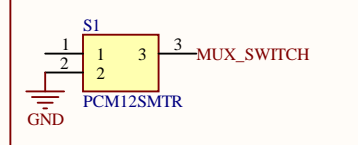

Title POWER		
Size Letter	Number	Revision
Date: 3/26/2020	Sheet of	
File: D:\OneDrive - Massachusetts Institute of Technology\...SHP\PC12SYS\CH04\LEK		

THERMOPILE CIRCUIT

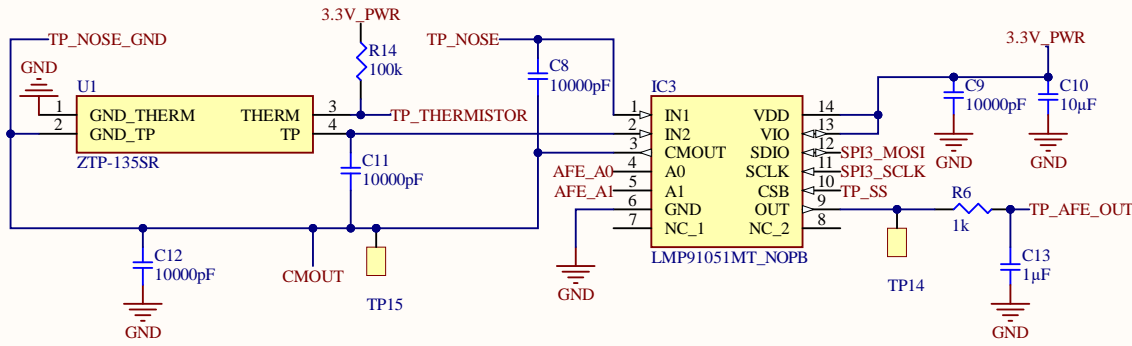

LOW-PASS FILTER

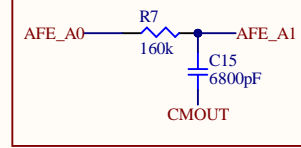

IMU

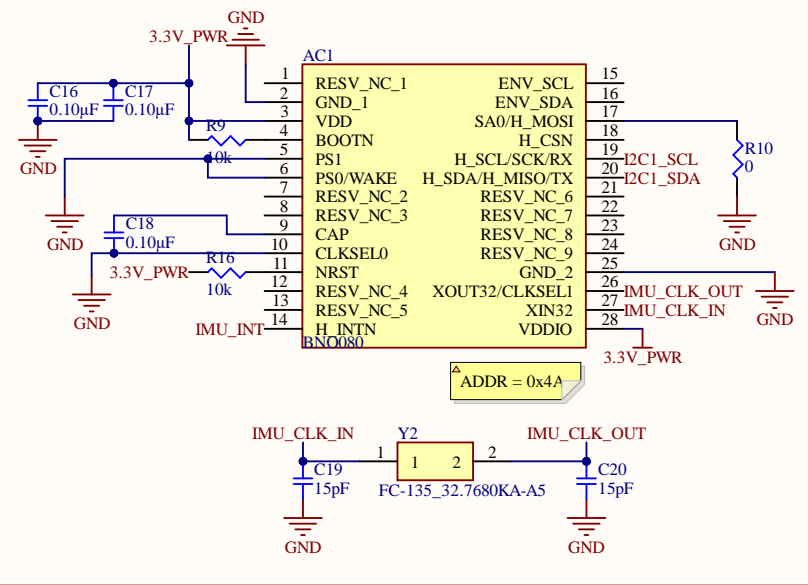

MICROPHONE CIRCUIT

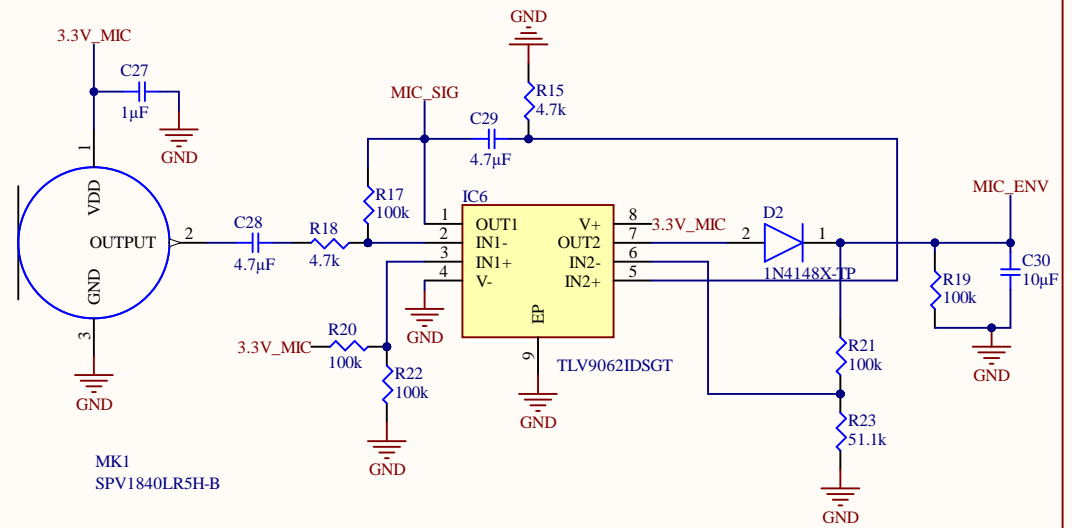

VIVE DIODE

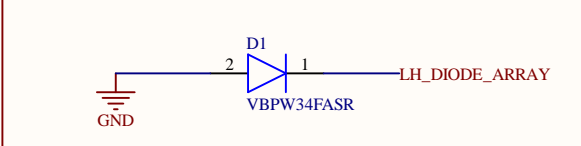

SENSORS

Size	Number	Revision
Letter		
Date:	3/26/2020	Sheet of
File:	D:\OneDrive - Massachusetts Institute of Technology\... \CATS\krcs\BDD\K	1 of 1

